

AD-785 837

CAVITATION PERFORMANCE OF A PROPELLER
DESIGN FOR A NAVAL AUXILIARY CILER
(AO 177) (MODEL 5326 WITH DESIGN PROPELLER
4645)

K. Remmers, et al

Naval Ship Research and Development Center

Prepared for:

Naval Ship Engineering Center

September 1974

DISTRIBUTED BY:

NTIS

National Technical Information Service
U. S. DEPARTMENT OF COMMERCE
5285 Port Royal Road, Springfield Va. 22151

The Naval Ship Research and Development Center is a U. S. Navy center for laboratory effort directed at achieving improved sea and air vehicles. It was formed in March 1967 by merging the David Taylor Model Basin at Carderock, Maryland with the Marine Engineering Laboratory at Annapolis, Maryland.

Naval Ship Research and Development Center
Bethesda, Md. 20034

MAJOR NSRDC ORGANIZATIONAL COMPONENTS

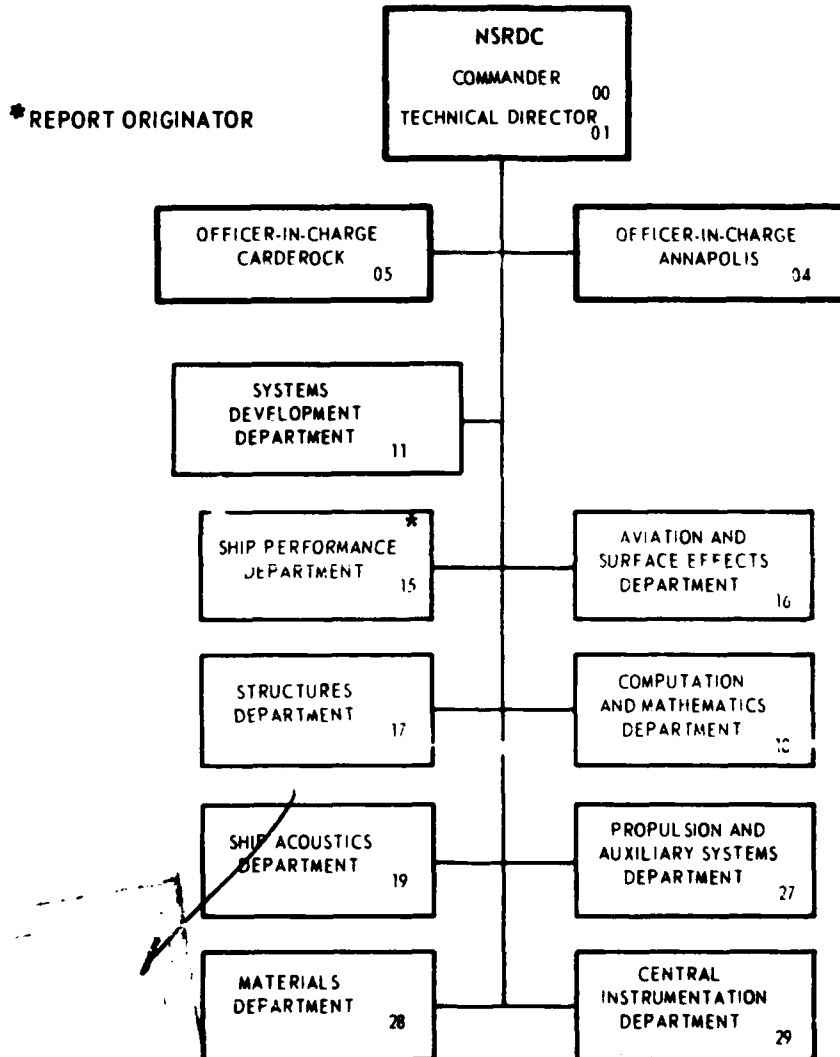

Handwritten notes and a signature are present in the bottom left corner. A signature is written over a rectangular box. The word "A" is written below the signature. The word "ib" is written in the center of the page.

ib

UNCLASSIFIED

SECURITY CLASSIFICATION OF THIS PAGE (When Data Entered)

AD 785 837

| REPORT DOCUMENTATION PAGE | | READ INSTRUCTIONS BEFORE COMPLETING FORM |
|---|-----------------------|--|
| 1. REPORT NUMBER SPD-544-11 | 2. GOVT ACCESSION NO. | 3. RECIPIENT'S CATALOG NUMBER |
| 4. TITLE (and Subtitle) CAVITATION PERFORMANCE OF A PROPELLER DESIGN FOR A NAVAL AUXILIARY OILER (AO 177) (MODEL 5326 WITH DESIGN PROPELLER 4645) | | 5. TYPE OF REPORT & PERIOD COVERED Final |
| 7. AUTHOR(s) K. REMMERS, N. A. MCDONALD, AND R. HECKER | | 8. CONTRACT OR GRANT NUMBER(s) |
| 9. PERFORMING ORGANIZATION NAME AND ADDRESS Naval Ship R&D Center, Ship Performance Dept., Bethesda, Md. 20084 | | 10. PROGRAM ELEMENT, PROJECT, TASK AREA & WORK UNIT NUMBERS O&MN Work Unit 1524-535 |
| 11. CONTROLLING OFFICE NAME AND ADDRESS Naval Ship Engineering Center Hyattsville, Md. 20782 | | 12. REPORT DATE SEPTEMBER 1974 |
| 14. MONITORING AGENCY NAME & ADDRESS (if different from Controlling Office) | | 13. NUMBER OF PAGES 25 |
| | | 15. SECURITY CLASS. (of this report) UNCLASSIFIED |
| | | 15a. DECLASSIFICATION/DOWNGRADING SCHEDULE |
| 16. DISTRIBUTION STATEMENT (of this Report) Approved for public release; distribution unlimited | | |
| 17. DISTRIBUTION STATEMENT (of the abstract entered in Block 20, if different from Report) | | |
| 18. SUPPLEMENTARY NOTES Reproduced by NATIONAL TECHNICAL INFORMATION SERVICE U.S. Department of Commerce Springfield, VA 22151 | | |
| 19. KEY WORDS (Continue on reverse side if necessary and identify by block number) propeller cavitation performance | | |
| 20. ABSTRACT (Continue on reverse side if necessary and identify by block number) Cavitation experiments were performed on a model propeller designed for (AO 177). The results showed satisfactory performance concerning power loss however a potential problem with erosion is predicted based on these results. Additional erosion studies are recommended. | | |

DD FORM 1473
1 JAN 73EDITION OF 1 NOV 68 IS OBSOLETE,
S/N 0102-014-6601

UNCLASSIFIED

1. SECURITY CLASSIFICATION OF THIS PAGE (When Data Entered)

25

NOTATION

| | |
|-----------|--|
| BTF | Blade thickness fraction |
| c | Propeller blade section length |
| $c_{0.7}$ | Propeller blade section length at 0.7R |
| C_o | Maximum chordwise camber |
| C_A | Correlation Allowance |
| C_F | Frictional resistance coefficient, $R_F/1/2 \rho V^2 S$ |
| C_R | Residuary resistance coefficient, $R_R/1/2 \rho V^2 S$ |
| C_T | Total resistance coefficient, $R_T/1/2 \rho V^2 S$ |
| D | Propeller diameter |
| EAR | Expanded area ratio, A_E/A_0 |
| g | Acceleration due to gravity |
| H | Total head at shaft centerline, less vapor pressure |
| H_L | Total local head, less vapor pressure |
| J | Advance coefficient of propeller, V_i/nD |
| J_L | Advance coefficient of propeller, local wake, $\frac{V_x}{(nD) + \left(\frac{V_t}{(r/R)\pi}\right)}$ |
| J_T | Advance coefficient based on thrust identity |
| J_V | Advance coefficient based on ship speed V/nD |
| K_Q | Torque coefficient $Q/\rho n^2 D^5$ |
| K_T | Thrust coefficient $T/\rho n^2 D^4$ |

NOTATION
(continued)

| | |
|-------|---|
| n | Rate of revolution |
| P | Propeller pitch |
| P_E | Effective horsepower |
| P_S | Shaft horsepower |
| Q | Torque |
| R_n | Reynolds number for propeller, $c \frac{0.7 \sqrt{V_A^2 + (0.7 \pi n D)^2}}{\nu}$ |
| R_F | Frictional resistance |
| R_R | Residuary resistance |
| R_T | Total resistance |
| r/R | Nondimensional propeller radius |
| S | Wetted surface |
| t | Thrust deduction fraction, $(T-R_T)/T$ |
| t_m | Maximum chordwise thickness |
| T | Thrust |
| V | Ship speed |
| V_A | Propeller inflow velocity |
| V_t | Local tangential velocity |
| V_x | Local longitudinal velocity |
| w_T | Taylor wake fraction determined from thrust identity |
| w_Q | Taylor wake fraction determined from torque identity |

NOTATION
(continued)

| | |
|------------|--|
| η_H | Hull efficiency |
| η_O | Propeller efficiency in open water |
| η_P | Propeller efficiency behind the hull |
| η_R | Relative rotative efficiency |
| η_S | Propulsive efficiency, P_E/P_S |
| θ_S | Projected skew angle |
| ν | Kinematic viscosity |
| ρ | Density |
| σ | Cavitation number based on vapor pressure, $2gH/V^2$ |
| σ_L | Cavitation number based on vapor pressure, local wake and head, $2gH_L/V_X^2$ |

ADMINISTRATIVE INFORMATION

This work was performed at the Naval Ship Research and Development Center (NSRDC), Bethesda, Maryland 20084. The project was authorized by the Naval Ship Engineering Center (NAVSEC), ltr 6136C/DMC 9290, Ser 90, 17 May 1974, and was funded under Purchase Order 4-0118, Amendment 1, 17 April 1974, NSRDC Work Unit 1524-535.

INTRODUCTION

The Naval Ship Engineering Center initiated a physical model experimental program at NSRDC to aid in the evaluation of a design propeller for a Naval Auxiliary Oiler (AO).¹

PROCEDURE AND RESULTS

The propeller evaluated, NSRDC Model Propeller 4645, was a fixed pitch, 9.812 inch diameter propeller which represents a 21 foot propeller full scale. Baseline experiments were conducted with stock Propeller 4572A which represented about a 23 foot diameter propeller. After a thorough investigation was performed at NSRDC, it was decided by NSRDC (Code 1544) and NAVSEC (Code 6144) to reduce the diameter from 23 feet to 21 feet. Details of the design of the AO-177 propeller can be found in Reference 2. A drawing of this propeller is presented in Figure 1. Table 1 gives the geometry of the propeller. This report presents the open-water and cavitation experimental evaluation for the propeller. The open-water experiment was performed to provide predictions of propeller performance for use in the propulsion experiments³, and to calibrate tunnel velocity for the

*References are listed on page 7 .

cavitation experiment. The cavitation experiments were performed to determine the type and extent of propeller cavitation in order to predict its effect on ship powering and the possibility of blade erosion.

The open-water experiment was performed with the Center's standard propeller boat in the deep-water basin, using a one horsepower gravity type dynamometer. The experiment was performed at Reynolds Numbers greater than 5.0×10^5 to insure turbulent flow over the propeller blades. Thrust and torque were measured, while the rate of revolution was varied from 10.0 to 14.5 rps and velocity was varied from 5 to 12 fps. Velocity and rate of revolution were determined to within 0.01 fps and rps. Thrust and torque measurements were accurate to within ± 0.2 pounds or inch-pounds.

The cavitation experiments were conducted in the closed-jet test section of the Center's 24-inch Variable Pressure Water Tunnel in a nonuniform flow field produced by a wire grid. This wake screen, located 30 inches upstream of the propeller, was designed⁴ to produce at the propeller the longitudinal wake components predicted from the wake survey behind the hull model. A plot of the longitudinal wake components which the screen was designed to produce is shown in Figure 2 compared to the AO-177 longitudinal wake. Figure 3 shows a photograph of the tunnel experimental set-up. The propeller was powered, and thrust and torque were measured by the 150-hp downstream dynamometer. Test section velocity, 14 fps, was calibrated for each advance coefficient (J) by using the thrust coefficients (K_T) from the open-water characteristics. The calibration was performed by setting the rate of revolution for the advance coefficient and adjusting the water speed until the thrust coefficient at the propeller disk was the same as the open-water thrust coefficient. This calibrated velocity was held constant and static pressure varied to change cavitation number.

The cavitation experiment were conducted over a range of cavitation numbers, (σ) from 15.3 to 1.9 while including ship speeds from 14 to 24 knots, based on a full-scale submergence of 21.49 feet to the shaft centerline. The experiment covered a range of advance coefficients from 0.7 to 1.2.

Thrust, torque, velocity, rate of revolution, and pressure were recorded during the experiment. The accuracy of measurements were: thrust, ± 0.5 pound; torque, ± 0.1 foot-pound; velocity, within 0.1 fps of the average test section velocity; rate of revolution, ± 0.01 rps; and static pressure, ± 0.01 inch of mercury. The air content of the tunnel water was held as nearly as possible at 30% of atmospheric saturation (measured by Van Slyke apparatus) in order to provide clear visibility throughout the cavitation number range. Water temperature varied from 96° to 108° Fahrenheit during the testing period.

DISCUSSION

Results of the open-water experiment are shown in Figure 4 and Table 2 in nondimensional coefficients of thrust (K_T), torque (K_Q), and efficiency (η_0) over a range of advance coefficients (J).

Results of the cavitation experiment are shown in Figure 5. All coefficients are based on velocity at the propeller. These curves are based on visual observations. The inception curve is based on the first condition, i.e., highest cavitation index and lowest advance coefficient (back cavitating)* and any circumferential position, at which cavitation of a particular type is observed. The area above any curve indicates that no cavitation of that type was visible at these conditions anywhere around the disk. Below the

*The observation would be highest advance coefficient for face cavitation.

curve the cavitation intensity increases with decreasing cavitation number. Also shown, are two curves based on propulsion data for correlation allowances of 0.0005 and 0.0012, adjusted for mean wake. Along these curves, ship speed is indicated in knots. Cavitation sketches are presented in Figures 6 through 8 showing observed cavitation for ship speeds of 20, 21, 21.5, 22 and 23 knots with $C_A = .0005$. These figures present cavitation sketches showing changes in cavitation intensity due to the nonuniform flow produced by the simulated model wake. The angles on the sketches indicate areas of from no cavitation to maximum cavitation and back to no cavitation. Figure 3 is a photograph of the typical cavitation patterns observed for ship speeds up to about 22 knots. This photo shows back cavitation as caused by the high wake region behind the hull. Tip vortex is weak. Back cavitation appears and disappears as the propeller blades pass through the high wake region behind the hull. This back cavitation must therefore form and collapse each cycle of the propeller through the wake. The photo shows a white mist as the cavity is collapsing which could be a potential erosion problem (discussed later). Hub vortices could not be evaluated due to the downstream driving experimental setup. Typical face and back bubble cavitation at off design conditions is shown in the photographs of Figure 9. Face cavitation in these conditions flashed on with tip vortex down to 0.8 radius near the leading edge and off the surface of the blade. Face cavitation was very noisy and could be heard before it was visible. Bubble cavitation inception was observed beyond the operating speed range. Large bubbles appeared near the leading edge and propagated up the midchord of the blades. These bubbles started just outside of the high wake region where no back and sheet cavitation had occurred and as the pressure was reduced, these bubbles entered into the sheet cavitation in the high wake region.

From Figure 5 the inception speed of various types of cavitation are predicted for $C_A = .0005$ below:

| <u>Type</u> | <u>Speed</u> |
|--|--------------------|
| Initial Back Sheet 0.95 R | ~ 15 knots |
| Back Sheet 0.8 R | ~ 20.7 knots |
| Back Bubble | > 22 knots |
| Face Sheet | does not intersect |
| Tip Vortex (uncorrected for R_n) (Back) | ~ 15 knots |
| Tip Vortex (corrected for R_n) (Back) | ~ 9.5 knots |
| Tip Vortex (uncorrected for R_n) (Face) | does not intersect |
| Tip Vortex (corrected for R_n) (Face) | ~ 14.5 knots |

Based on the data obtained and the inception speeds there is no measurable power loss due to cavitation.

Normally the type of cavitation observed is considered to present little problem in erosion. Sheet cavitation extending to about 0.75 radius at the extreme conditions as the propeller passes through the high wake region is typical of this type propeller. Upon removing the propeller after completion of the experiments (about 20 hours of tunnel running time), it was observed to have pitting of the anodized surface near the 0.9 radius trailing edge. Figure 10 shows photographs of the area mentioned. While no conclusive data is available, it has been observed in the past that after 40 hours of testing model propellers in the water tunnel, if no pitting of the anodizing is indicated, no erosion problems are likely. But, in this case, if pitting is observed, there is a strong possibility that full scale erosion may be a potential problem. There is one mitigating circumstance which should be checked out. Due to a heavy test schedule at NSRDC the tunnel water temperature

reached 108° Fahrenheit. It is known that increasing temperature increases rate of erosion. B. W. Hansen and R. E. H. Rasmussen⁵ show the erosion of aluminum specimens increases from 40° to at least 112° Fahrenheit due to cavitation. In the range of temperatures the tunnel experiments were performed (96° to 108°F), the increase in erosion rate over the normal temperatures of the tunnel water is about 17% as shown by Hansen. With an exposure of less than 50% of the normal safe no-erosion test and with a predicted 17% increase in erosion rate, it is predicted that there is a possibility of an erosion problem with this propeller. Hence, some additional erosion work should be performed to further evaluate the erosion problem.

REFERENCES

1. NAVSEC Revision No. 1 of "AO 177 Class Model Test Plan for Contract Design Phase," 22 April 1974.
2. Valentine, D. and Chase, A., "Highly Skewed Propeller Design for a Naval Auxiliary Oiler (AO-177)," NSRDC Report in Preparation
3. Murray, L. and Hecker, R., "Powering Predictions of a Naval Auxiliary Oiler (AO-177) (Model 5326 with Design Propeller 4645)," NSRDC Report SPD-544-10 (Sep 1974).
4. McCarthy, J. H., "Steady Flow Past Nonuniform Wire Grids," Journal of Fluid Mechanics, Vol. 19, Part 4 (1964).
5. Hansen, B. W. and Rasmussen, R.E.H., "Cavitation Damage Experiments in a Rotating Disk Apparatus Especially with Regard to the Gas Content of Water," Journal of Ship Research, June 1968. pp. 83-87.

TABLE 1
DESIGN DATA PROPELLER 4645

Diameter = 252.000 inches

| r/R | Chord Length Inches | c/D | Pitch Inches | P/D | Maximum Thickness Inches | t _m /D | Maximum Camber Inches | C _o /D | Skew Inches | θ S | Forward Rake Inches |
|------|---------------------|-------|--------------|-------|--------------------------|-------------------|-----------------------|-------------------|-------------|--------|---------------------|
| 0.2 | 52.164 | 0.207 | 284.256 | 1.128 | 10.4328 | 0.0414 | 3.0203 | 0.0120 | 0.000 | 0.000 | 0.0 |
| 0.3 | 58.464 | 0.232 | 316.008 | 1.254 | 10.3481 | 0.0411 | 2.7361 | 0.0109 | -3.077 | -2.802 | 0.598 |
| 0.4 | 52.748 | 0.249 | 334.908 | 1.329 | 9.7573 | 0.0387 | 2.4095 | 0.0100 | -0.257 | -0.201 | 0.026 |
| 0.5 | 64.764 | 0.257 | 341.208 | 1.354 | 8.6784 | 0.0344 | 2.2020 | 0.0087 | 8.708 | 5.999 | -0.936 |
| 0.6 | 63.756 | 0.253 | 336.420 | 1.335 | 7.1725 | 0.0285 | 2.2123 | 0.0088 | 23.448 | 14.502 | -1.621 |
| 0.7 | 58.958 | 0.234 | 315.000 | 1.250 | 5.3661 | 0.0213 | 2.0049 | 0.0080 | 44.263 | 24.998 | -1.042 |
| 0.8 | 49.392 | 0.196 | 282.240 | 1.120 | 3.4130 | 0.0135 | 1.4620 | 0.0058 | 65.098 | 33.799 | 0.523 |
| 0.9 | 34.776 | 0.138 | 241.416 | 0.958 | 1.8640 | 0.0074 | 0.8312 | 0.0033 | 84.421 | 40.399 | 2.527 |
| 0.95 | 23.889 | 0.095 | 217.192 | 0.862 | 1.1995 | 0.0048 | 0.5065 | 0.0020 | 93.366 | 42.937 | 3.752 |
| 1.00 | 0.000 | 0.000 | 190.008 | 0.754 | 0.000 | 0.0000 | 0.000 | 0.0000 | 101.769 | 45.000 | 5.265 |

Section Meanline
 Section Thickness Distribution
 Expanded area ratio
 Projected area ratio
 Mean width ratio
 Blade thickness fraction
 Rake angle
 Projected Skew angle at blade tip
 Linear ratio

NACA a = 0.8
 NACA 66 MOD.
 0.754
 0.590
 0.211
 0.062
 2.402
 44.999
 25.682

TABLE 2

FAIRED OPEN WATER COEFFICIENTS

PROPELLER 4645

| J | K_T | $10K_Q$ | η_o |
|-------|-------|---------|----------|
| 0.000 | 0.579 | 0.913 | 0.000 |
| .050 | .561 | .890 | .050 |
| .100 | .544 | .869 | .100 |
| .150 | .527 | .849 | .148 |
| .200 | .511 | .830 | .196 |
| .250 | .494 | .812 | .242 |
| .300 | .477 | .794 | .287 |
| .350 | .460 | .777 | .330 |
| .400 | .443 | .760 | .371 |
| .450 | .426 | .742 | .411 |
| .500 | .408 | .724 | .449 |
| .550 | .390 | .705 | .484 |
| .600 | .372 | .686 | .518 |
| .650 | .353 | .665 | .549 |
| .700 | .334 | .643 | .578 |
| .750 | .314 | .620 | .604 |
| .800 | .293 | .595 | .627 |
| .850 | .271 | .567 | .647 |
| .900 | .249 | .538 | .663 |
| .950 | .226 | .506 | .674 |
| 1.000 | .201 | .471 | .680 |
| 1.050 | .176 | .433 | .679 |
| 1.100 | .150 | .393 | .668 |
| 1.150 | .122 | .348 | .643 |
| 1.200 | .094 | .300 | .596 |
| 1.250 | .064 | .249 | .509 |
| 1.300 | .032 | .193 | .347 |
| 1.350 | 0.000 | .133 | 0.000 |

$$K_T = \begin{aligned} &.34240 \\ &-.26379 (L) \\ &-.05491 (L^{*2}) \\ &-.02754 (L^{*3}) \end{aligned}$$

$$10K_Q = \begin{aligned} &.65353 \\ &-.29792 (L) \\ &-.13386 (L^{*2}) \\ &-.09541 (L^{*3}) \end{aligned}$$

WHERE $L = (1.47605)(J) - 1.0000$

PROPELLER 4645

| | | | |
|------------------|-------|----------------|------------|
| Number of Blades | 6 | Diameter | 9.812 in. |
| Exp. Area Ratio | 0.754 | Fitch at 0.7 R | 12.265 in. |
| MAR | 0.211 | Rotation | R.H. |
| BTF | 0.962 | Designed by | NSFDC |
| P/D at 0.7 R | 1.250 | Reference | P 4645 |

Reproduced from
best available copy.

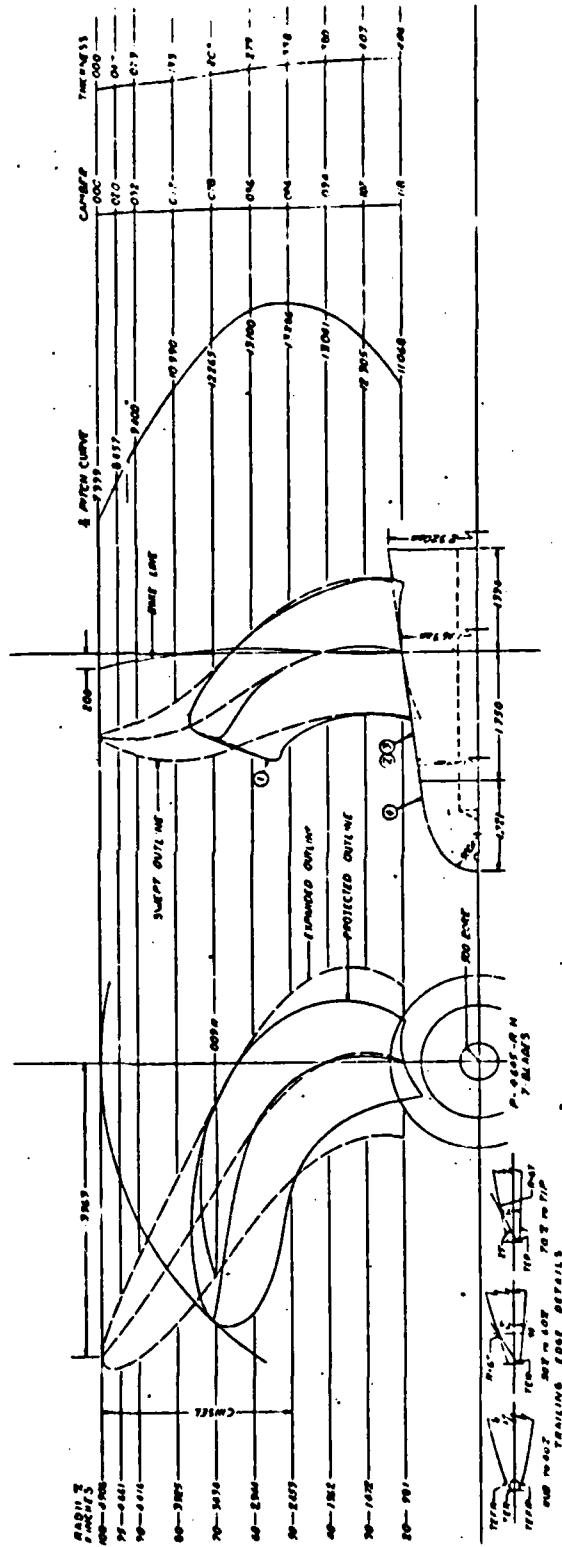
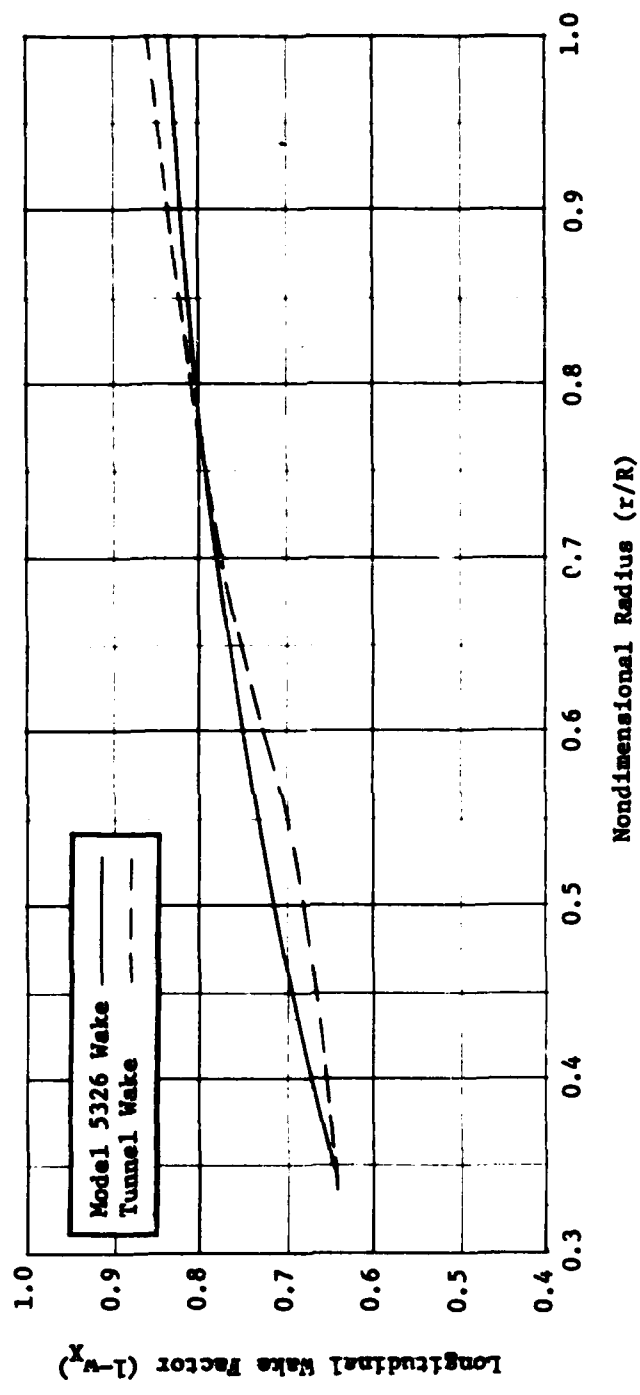

FIGURE 1

AO 177 Auxiliary Oiler
Propeller Diameter 21 Feet



WAKE DISTRIBUTION COMPARISON BETWEEN MODEL 5326
AND 24 INCH WATER TUNNEL WITH WAKE SCREEN

FIGURE 2



SETUP AND TYPICAL CAVITATION

FIGURE 3

12.

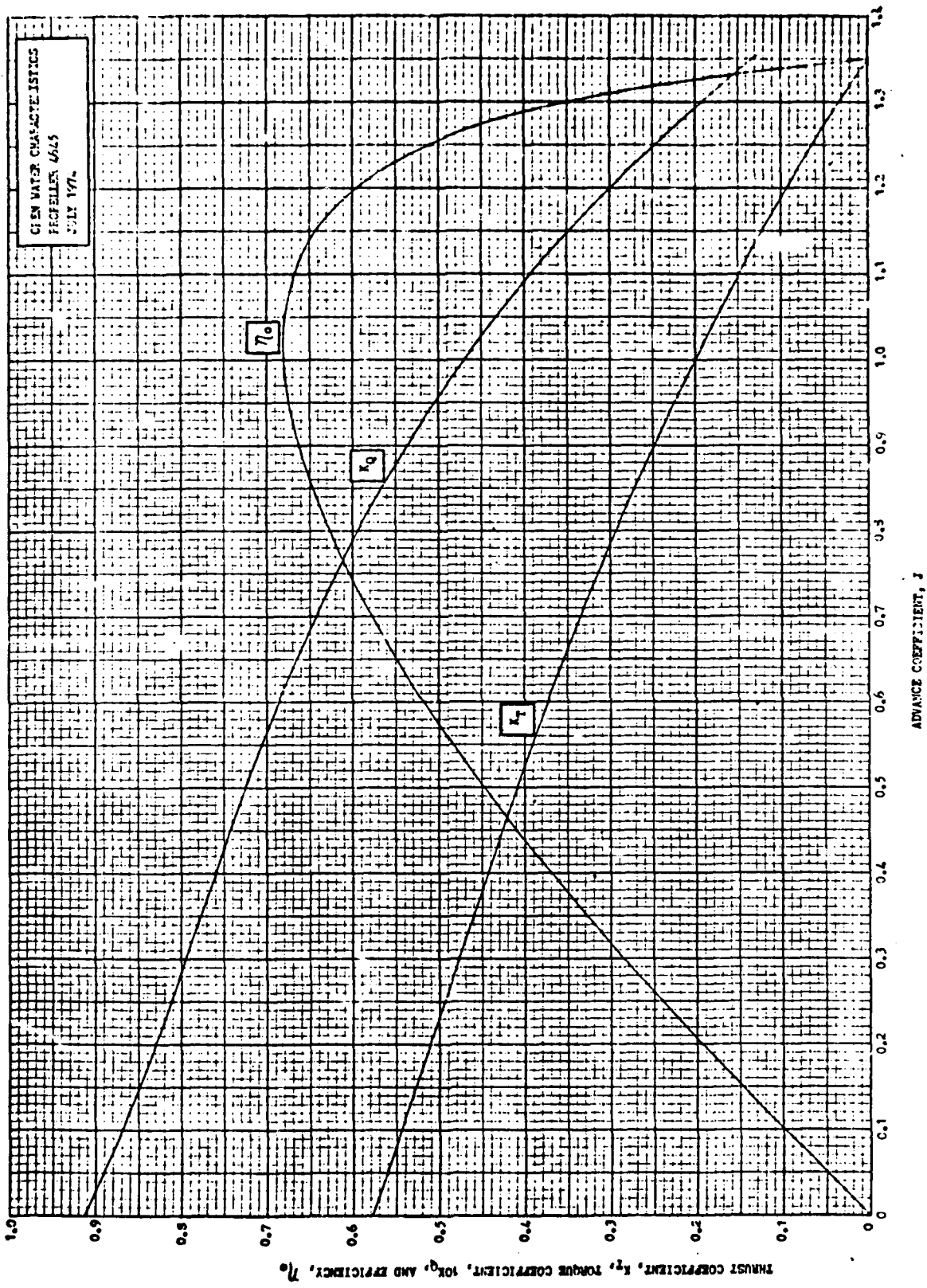

13.
FIGURE 4

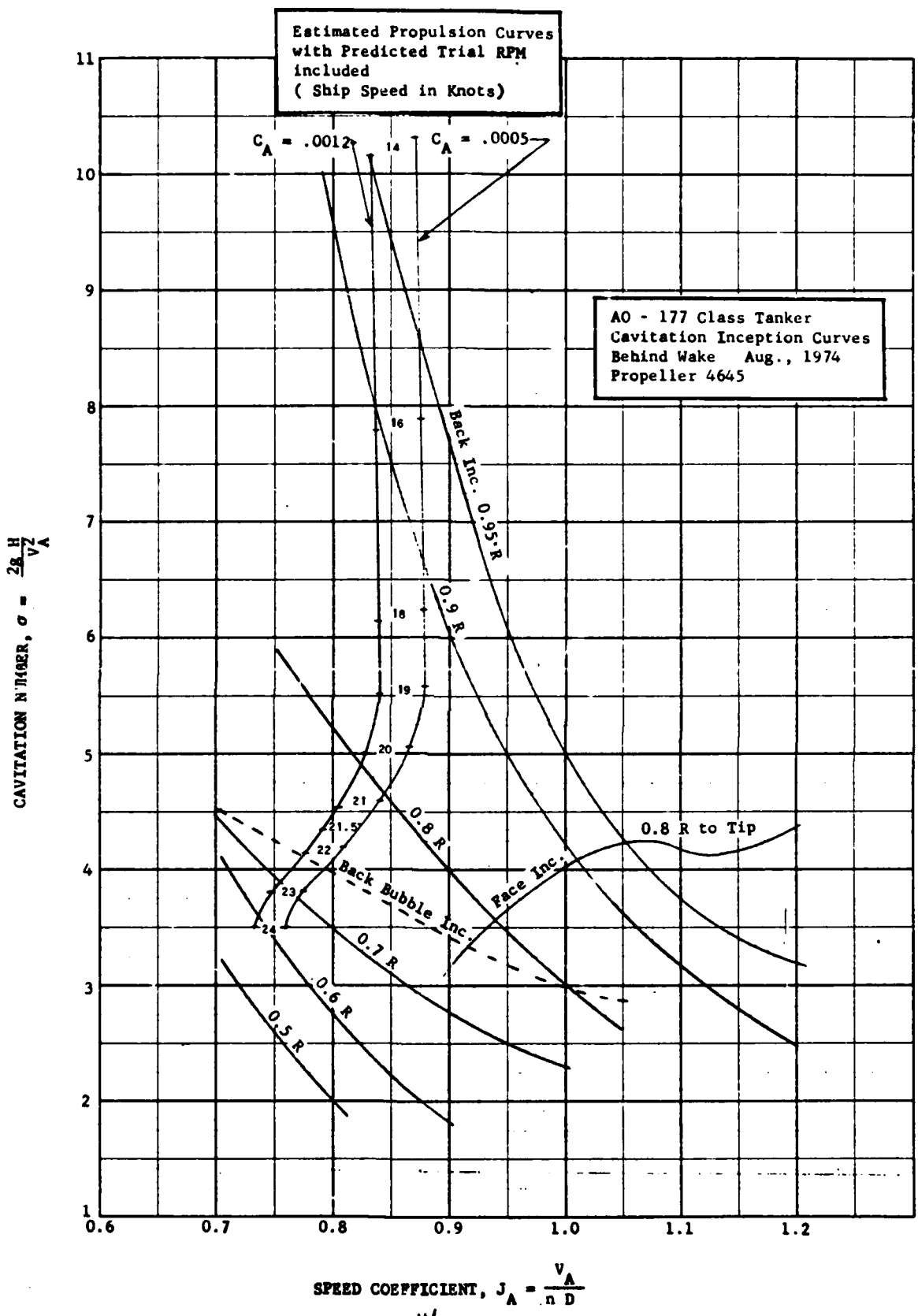

14
FIGURE 5

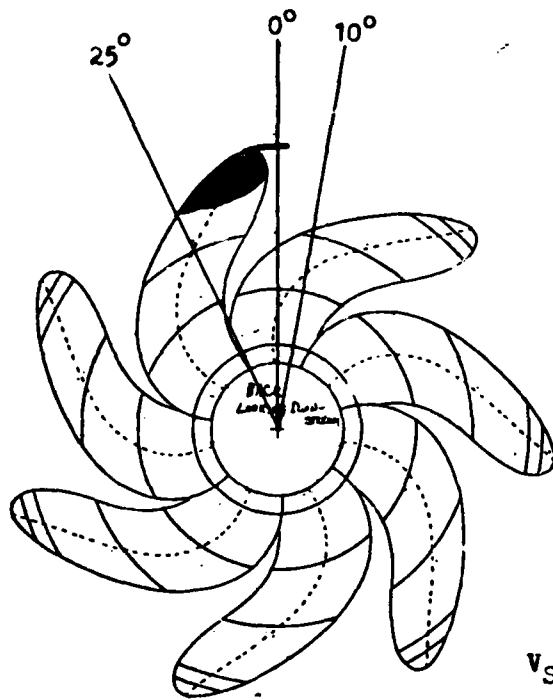

$V_S = 20$ knots

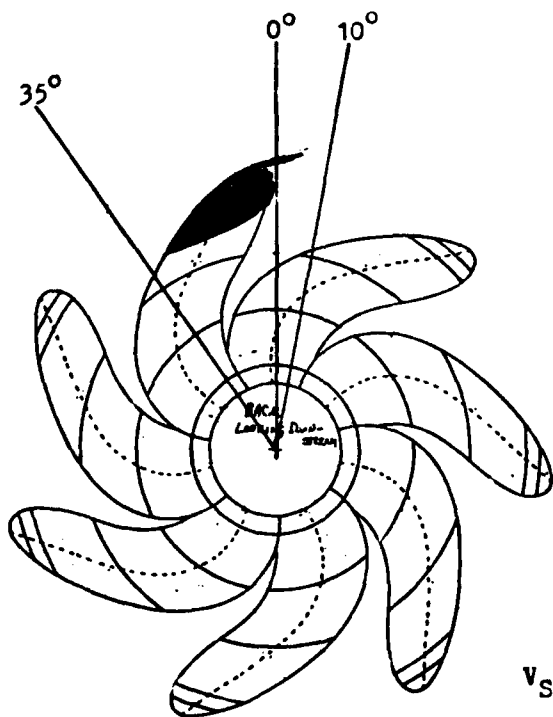

$V_S = 21$ knots

15

FIGURE 6

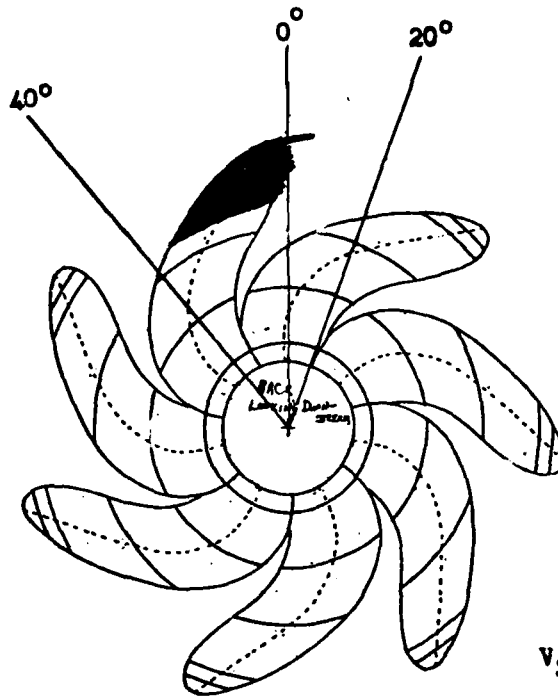

$V_S = 21.5$ knots

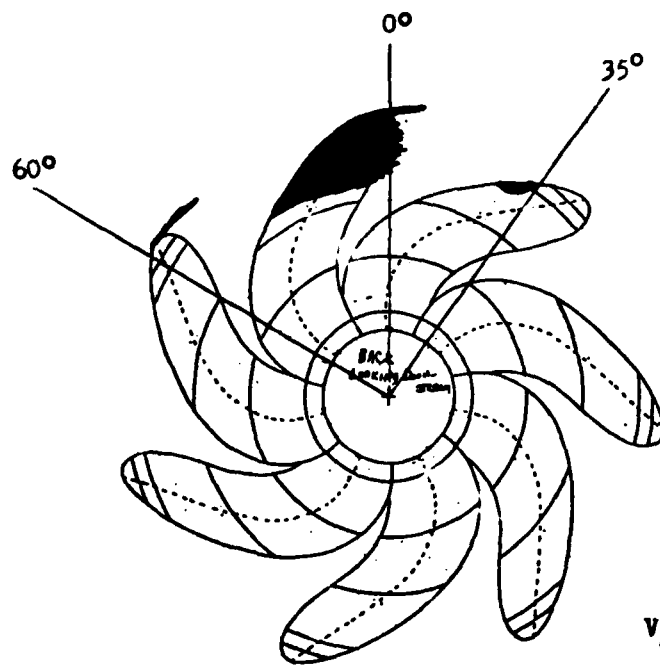

$V_S = 22$ knots

16
FIGURE 7

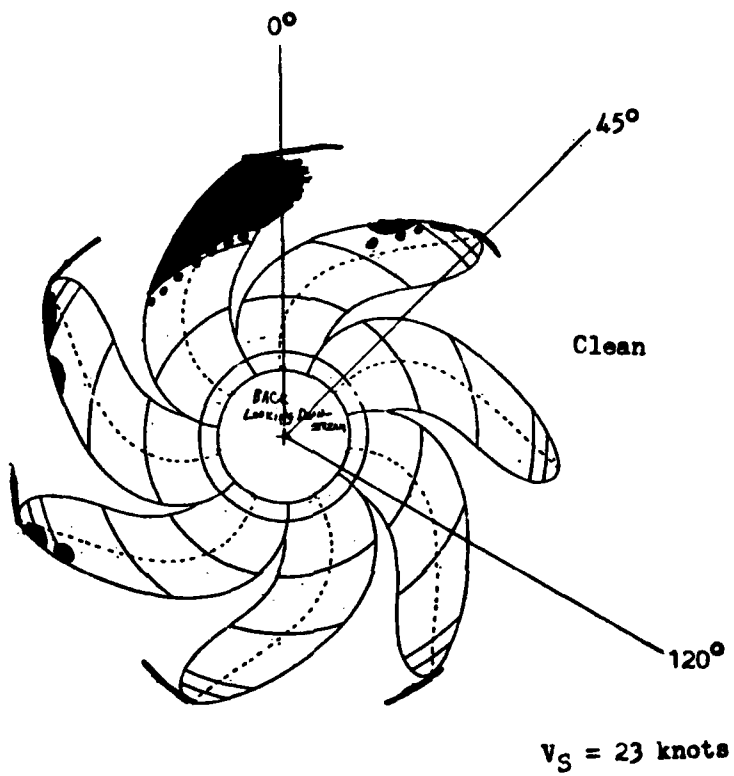

17.
FIGURE 8



BUBBLE CAVITATION



FACE CAVITATION

18

FIGURE 9



PSD 341573

19.
FIGURE 10